

Low Voltage Differential (LVD) SCSI 9 Line Terminator

FEATURES

- First LVD only Active Terminator
- Meets SCSI SPI-2 Ultra-2 (Fast-40) and Ultra-3 (Fast-80) Standby
- 2.7V to 5.25V Operation
- Differential Failsafe Bias

DESCRIPTION

The UCC5640 is an active terminator for Low Voltage Differential (LVD) SCSI networks. This LVDs only design allows the user to reach peak bus performance while reducing system cost. The device is designed as an active Y-terminator to improve the frequency response of the LVD Bus. Designed with a 1.5pF channel capacitance, the UCC5640 allows for minimal bus loading for a maximum number of peripherals. With the UCC5640, the designer will be able to comply with the Fast-40 and Fast-80 SPI-2 specifications. The UCC5640 also provides a much-needed system migration path for ever improving SCSI system standards. This device is available in the 24 pin TSSOP for ease of layout use.

The UCC5640 is not designed for single ended or high volume differential systems.

BLOCK DIAGRAM

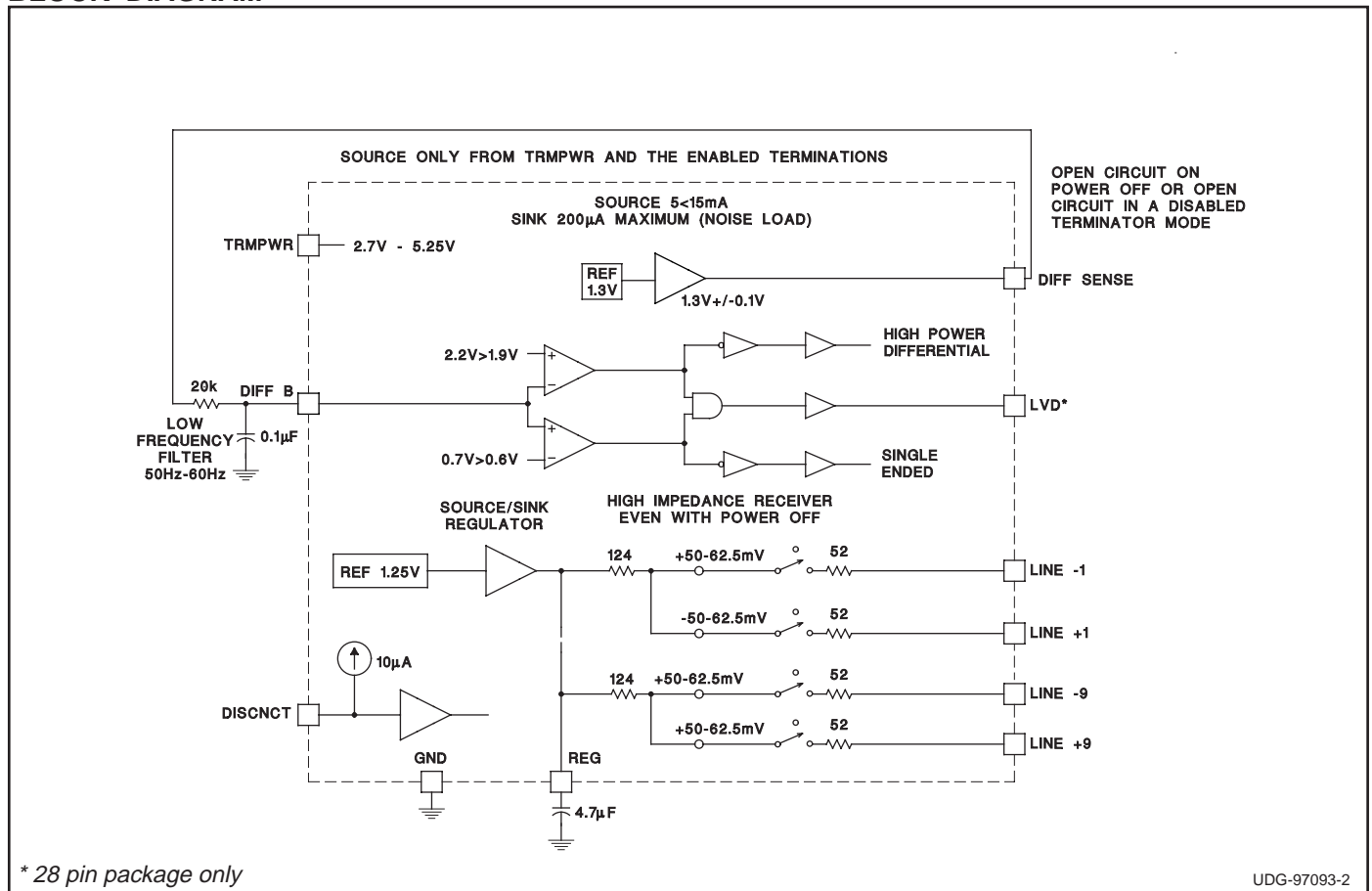

ABSOLUTE MAXIMUM RATINGS

TRMPWR Voltage. +6V
 Signal Line Voltage 0V to TRMPWR
 Package Dissipation 1W
 Storage Temperature -65°C to +150°C
 Junction Temperature -55°C to +150°C
 Lead Temperature (Soldering, 10 sec.) +300°C

Currents are positive into negative out of the specified terminal. consult Packaging Section of Databook for thermal limitations and considerations of package.

RECOMMENDED OPERATING CONDITIONS

TRMPWR Voltage 2.7V to 5.25V

CONNECTION DIAGRAMS

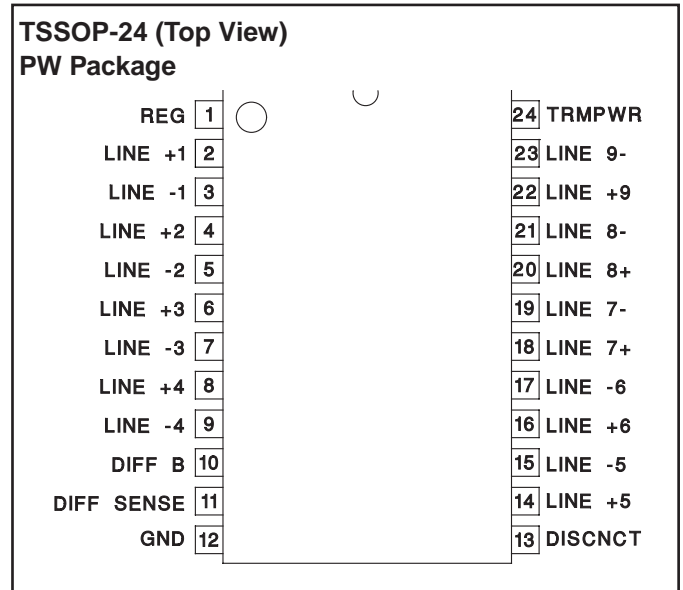

ELECTRICAL CHARACTERISTICS: Unless otherwise stated, specifications apply for TA = 0°C to 70°C, TRMPWR = 3.3V. TA = TJ.

PARAMETER	TEST CONDITIONS	MIN	TYP	MAX	UNITS
TRMPWR Supply Current Section					
TRMPWR Supply Current	No Load			25	mA
	Disabled Terminator			200	μA
TRMPWR Voltage		2.7		5.25	V
Regulator Section					
1.25V Regulator	DIFF SENSE connected to DIFF B	1.15	1.25	1.35	V
1.25V Regulator Source Current	DIFF SENSE connected to DIFF B	-80	-100		mA
1.25V Regulator Sink Current	DIFF SENSE connected to DIFF B	80	100		mA
1.25V Current Limit	DIFF SENSE connected to DIFF B	300			mA
1.3V Regulator	DIFF B connected to GND	1.2	1.3	1.4	V
1.3V Regulator Source Current	DIFF B to GND	-5		-15	mA
1.3V Sink Current	DIFF B to GND	50		200	μA
Differential Termination Section					
Differential Impedance	-2.5mA to 4.5mA	100	105	110	Ω
Common Mode Impedance	LINE+ connected to LINE-	110	150	165	Ω
Differential Bias Voltage	Drivers Tristated	100		125	mV
Common Mode Bias			1.25		V
Output Leakage, Disconnect	DISCNCT, TRMPWR = 0 to 5.25V, VLINE = 0.2 to 2.5V		10	400	nA
Output Capacitance	Single ended measurement to ground (Note 1)			3	pF
Disconnect & Differential Sense Input Section					
DISCNCT Threshold		0.8	0	2	V
Input Current	At 0V and 3.3V		10	30	μA
Differential Sense Signal Ended Threshold		0.6		0.7	V
Differential Sense LVD Threshold		1.9		2.2	V
Differential HP Differential Threshold		2.2			V

Note 1: Guaranteed by design. Not 100% tested in production.

PIN DESCRIPTION

DIFF B: Differential sense filter pin should be connected to a 0.1µF capacitor.

DIFF SENSE: The SCSI bus differential sense line to detect what type of devices are connected to the SCSI Bus.

DISCNCNT: Disconnect pin shuts down the terminator when it is not at the end of the bus.

GND: Ground.

LINE n-: Signal active line for single ended or negative line in differential applications for the SCSI Bus.

LINE n+: Ground line for single ended or positive line for differential applications for the SCSI Bus.

TRMPWR: V_{IN} 2.7V to 5.25V supply.

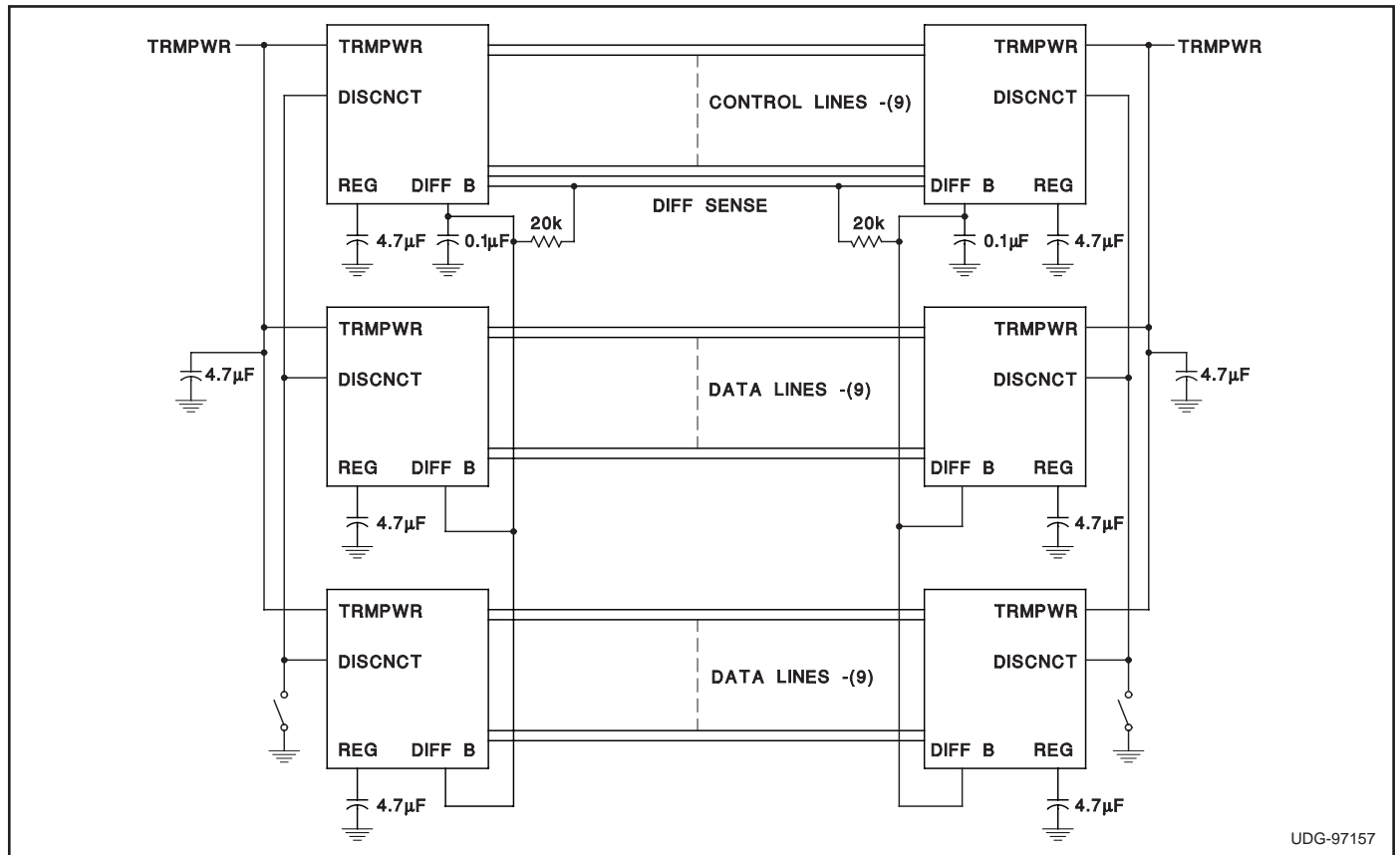

Figure 1. Application Diagram

UDG-97157